



TOUCHbasic-DN

Infinite Flexibility.

DESCRIPTION

The TOUCHbasic-down Handset offers an under-mounted TOUCH panel design and delivers simple and effective up and down movement control with large, comfortable buttons. The TOUCH panel, colors and print are customizable.

FEATURES

- Customizable Handset
- State of the art design
- Up / Down function
- Compact size
- Great button feel



Contact Headquarters

LOGICDATA Electronic & Software Entwicklungs GmbH
Wirtschaftspark 18, 8530 Deutschlandsberg, office.at@logicdata.net

North America

LOGICDATA North America Inc., 1525 Gezon Parkway SW,
Suite C Grand Rapids, MI 49509, USA, office.na@logicdata.net

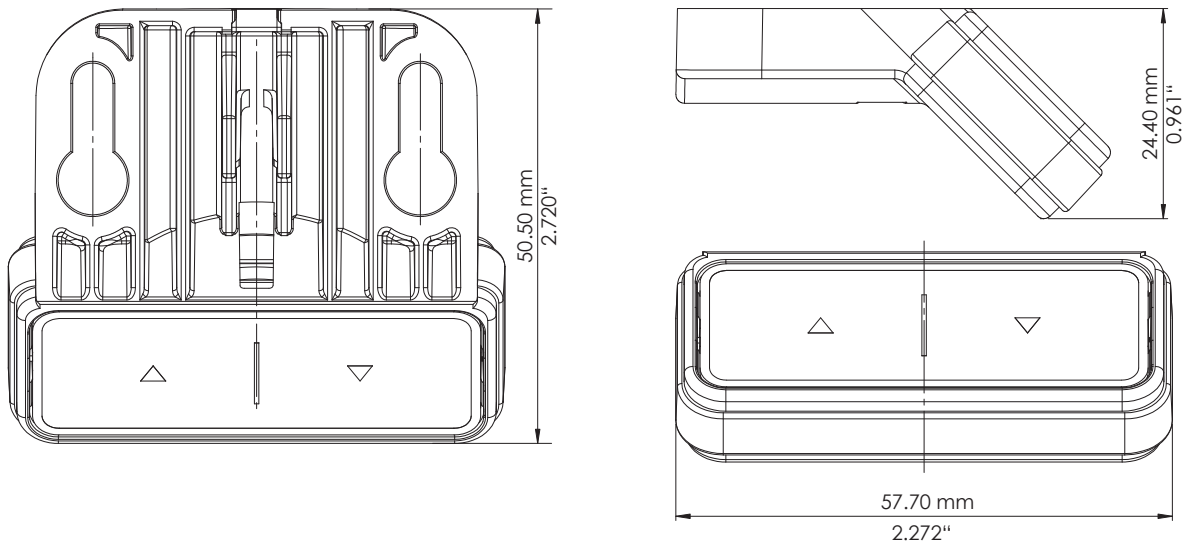

TECHNICAL DATA

Supply voltage	5 VDC \pm 10%
Current Consumption (average)	<1 mA
Rated switching current	50 mA
Service life	10 000 cycles
Cable length	1 800 mm / 70.866" (\pm 50 mm / 1.967")
Dimensions (l x w x h)	50.5 x 57.7 x 24.4 mm / 1.988 " x 2.272" x 0.961"
Weight (including cable)	70 g
Ambient conditions during operation	+5 °C to +40 °C at max. 68% relative air humidity (non-condensing), up to an altitude of 2,000 m.
Ambient conditions during transport and storage	-25 °C to +40 °C at max. 68% relative air humidity (non-condensing). +40 °C to 60 °C at max. 32% relative air humidity (non-condensing). Temperatures of more than 40 °C for periods not exceeding 10h. Product must be acclimatised to acceptable operating conditions before assembly. Contact LOGICDATA for exact specifications.
Compatibility	All LOGICDATA Control Boxes, except integrated Control Units in the LOGICdrive and DYNAMIC MOTION families
Degree of protection (IEC 60529)	IP 20
Standards and regulations	EMC directive 2014/30/EU RoHS directive 2011/65/EU
Order Code	TOUCH-Basic-UD-2-LD