



# SMARTneo

## Command and Control.

## DESCRIPTION

**Dominant.** The next generation in the growing dynasty of SMART Control Boxes by LOGICDATA, the SMARTneo is a content evolution of mechatronic technology: its slim, low-profile housing facilitating total freedom in design. Featuring an integrated, highly sensitive collision detection system, this (r)evolutionary product represents the best value all-in-one Control Box on the market today. Renowned Austrian quality, competitive prices.

## FEATURES

- 240 W output power
- Cost-effective SMPS
- Improved driving dynamics: increased responsiveness and smooth start/stop
- Integrated collision sensor with high sensitivity
- Sit/stand memory for Basic Hand Controls
- LOGICcell compatibility for standalone/mobile desk solutions
- Value-for-money 4-drive systems with optimized cascading handling
- Slim, low-profile design (height 35 mm)

### Contact Headquarters

LOGICDATA Electronic & Software Entwicklungs GmbH  
Wirtschaftspark 18, 8530 Deutschlandsberg, [office.at@logicdata.net](mailto:office.at@logicdata.net)

### North America

LOGICDATA North America Inc., 13617 Woodlawn Hills Dr.,  
Cedar Springs, MI 49319, USA, [office.na@logicdata.net](mailto:office.na@logicdata.net)



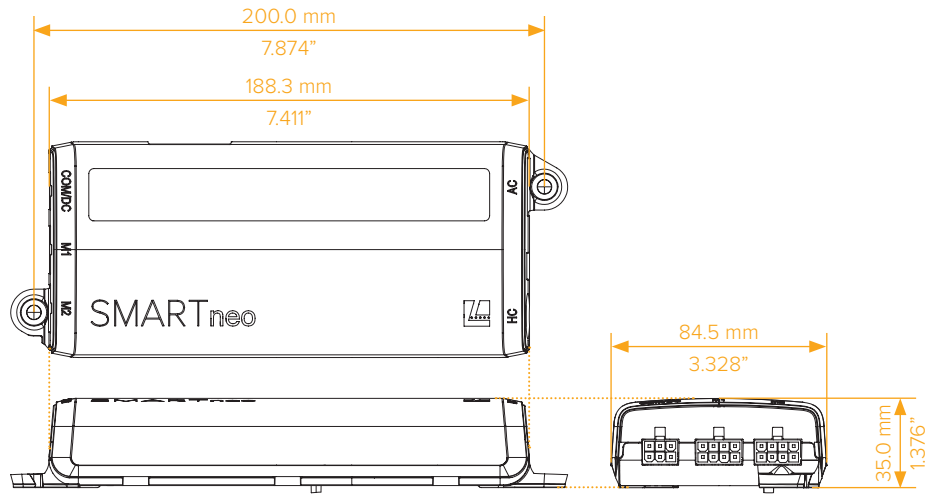

## TECHNICAL DATA

<b>Rated input current</b>	4 A
<b>Rated frequency</b>	50-60 Hz
<b>Rated input voltage</b>	100-120 VAC
<b>Rated output power</b>	240 W
<b>Duty cycle</b>	2 Min. ON (120W) / 18 Min. OFF or 0.5 Min. (240 W), 0.5 Min. (120W) / 9 Min. OFF
<b>Dimensions (l* x w x h )</b>	200.0 mm x 84.5 mm x 35.0 mm (7.874" x 3.328" x 1.376")
<b>Ambient conditions during operation</b>	+5 °C to +40 °C at max. 68% relative air humidity (non-condensing), up to an altitude of 2 000 m.
<b>Ambient conditions during transport and storage</b>	-25 °C to +40 °C at max. 68% relative air humidity (non-condensing). +40 °C to +60 °C at max. 32% relative air humidity (non-condensing). Temperatures of more than +40 °C for periods not exceeding 10h. Product must be acclimatised to acceptable operating conditions before assembly. Contact LOGICDATA for exact specifications.
<b>Compatibility</b>	Visit <a href="http://LOGICDATA.net">LOGICDATA.net</a> for a full list of compatible products.
<b>Degree of protection (IEC 60529)</b>	IP 20
<b>Applicable standards</b>	UL 60950-1, 2nd Edition, 2014-10-14   CAN/CSA C22.2 No. 60950-1-07, 2nd Edition, 2014-10   FCC Title 47 subpart 15 unintended radiator
<b>Interference immunity to ESD in accordance with EN 61000-6-2</b>	Contact discharge 4kV Air discharge 8kV
<b>Order code</b>	SMARTneo-2G-N-n-x-y-US

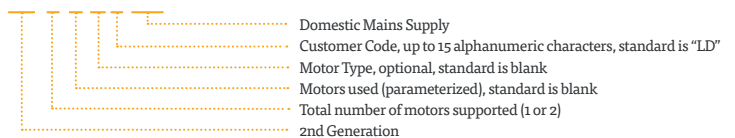

\*Length measured without Mounting Points. Length including Mounting Points: 218.9 mm  
Distance between Mounting Points: 200.0 mm (l) | 49.2 mm (w)