



SMARTneo 3G

Command and Control.

DESCRIPTION

Dominant. The next generation in the growing dynasty of SMART Control Boxes by LOGICDATA, the SMARTneo 3G is a confident evolution of mechatronic technology: its slim, low-profile housing facilitating total freedom in design. Featuring an integrated, highly sensitive gyro collision detection system with additional support for external sensor this (r)evolutionary product represents the best value all-in-one Control Box on the market today. Renowned Austrian quality, competitive prices.

FEATURES

- Integrated gyro collision sensor with high sensitivity and support for external sensor
- 240 W output power
- DC power input support
- Cost-effective SMPS
- Improved driving dynamics: increased responsiveness and smooth start/stop
- Sit/stand memory support
- Value-for-money 4-drive systems with optimized cascading handling
- Slim, low-profile design

Contact Headquarters

LOGICDATA Electronic & Software Entwicklungs GmbH
Wirtschaftspark 18, 8530 Deutschlandsberg, office.at@logicdata.net

North America

LOGICDATA North America Inc., 13617 Woodlawn Hills Dr.,
Cedar Springs, MI 49319, USA, office.na@logicdata.net



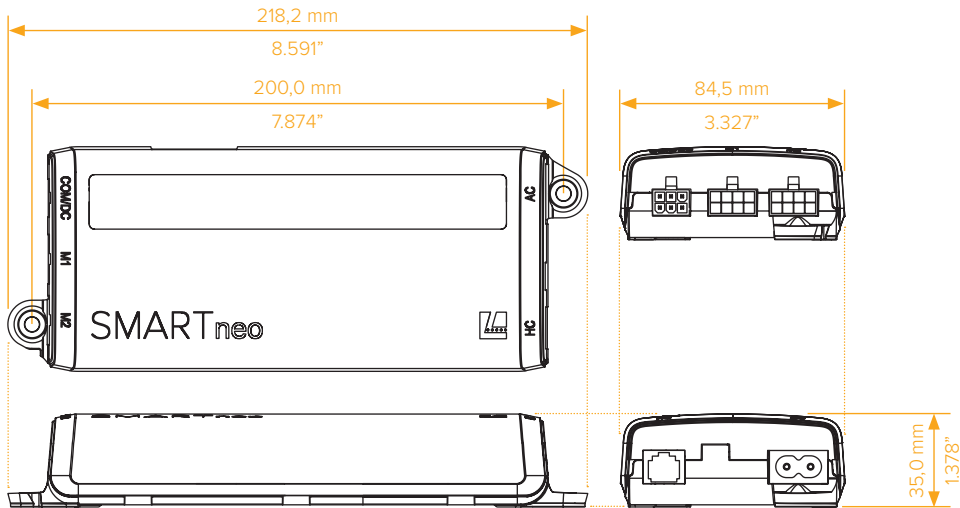

TECHNICAL DATA

| | |
|--|--|
| Rated input current | 2 A |
| Rated frequency | 50-60 Hz |
| Rated input voltage | 220-240 VAC |
| Rated output power | 240 W |
| Duty cycle | 2 Min. ON (120W) / 18 Min. OFF or 0,5 Min. (240 W), 0,5 Min (120W) / 9 Min. OFF |
| Dimensions (l x w x h) | 218,2 mm x 84,5 mm x 35,0 mm (8.591" x 3.327" x 1.378") |
| Ambient conditions during operation | +5 °C to +40 °C at max. 68% relative air humidity (non-condensing), up to an altitude of 2 000 m. |
| Ambient conditions during transport and storage | -25 °C to +40 °C at max. 68% relative air humidity (non-condensing). +40 °C to +60 °C at max. 32% relative air humidity (non-condensing). Temperatures of more than +40 °C for periods not exceeding 10h. Product must be acclimatised to acceptable operating conditions before assembly. Contact LOGICDATA for exact specifications. |
| Compatibility | Visit LOGICDATA.net for a full list of compatible products. |
| Degree of protection (IEC 60529) | IP 20 |
| Standards/Regulations | LVD directive 2014/35/EU EMV 2014/30/EU RoHS 2011/65/EU REACH Regulation (EC) Nr. 1907/2006 AfPS GS:2019 PAH |
| Applied standards | EN IEC 60335-1 EN ISO 13849-1 PLb EN 62233 EN 61000-3-2 EN 61000-3-3 EN 61000-6-2 EN 61000-6-3 |
| Order code | SMARTneo-3G-N-n-x-y-EU |

3rd Generation Domestic Mains Supply
 Total number of motors supported (1 or 2) Customer Code, up to 15 alphanumeric characters, standard is "LD"
 Motors used (parameterized), standard is blank Motor Type, optional, standard is blank